

1

2

3

4

5

**SEMI-FINISHED
SC ADAPTER PLATES**

8289

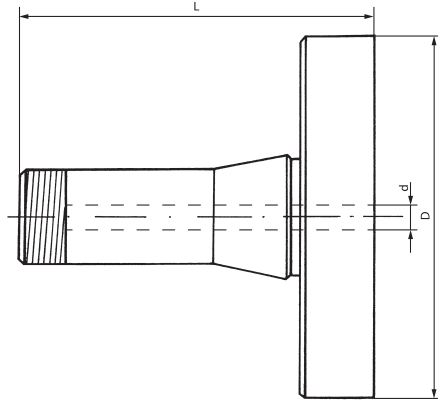

D - Chuck diameter

Code No.	D	Shank	Hole diameter [in]	L [in]	Thread
7-909-304	3" 4"	5C	0.87	4.41	1-1/4 - 20
7-909-305	5" 6"	5C	0.87	4.41	1-1/4 - 20