

- FORGED STEEL BODY
- PLAIN BACK TRU-LENGTH OR DIRECT THREADED MOUNT

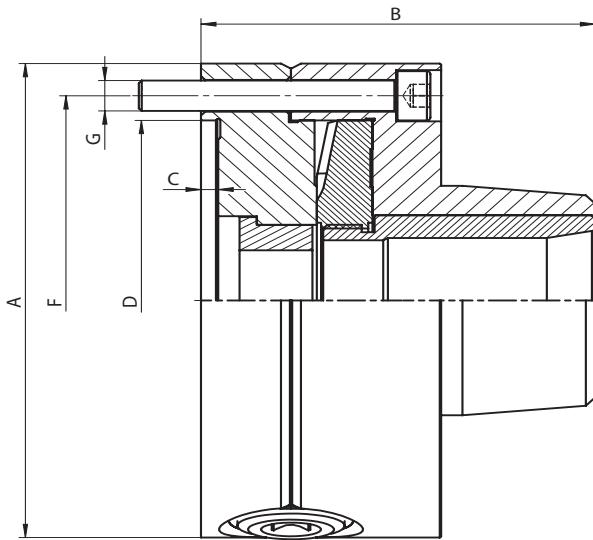

- High precision collet chucks
- TRU-LENGTH - fixed collet position
- Plain back mounting
- The wrench operated scroll provides for uniform and distortion free clamping of workpieces while simultaneously allowing for a fast collet exchange
- Designed for use with 5C collets (385E) and can be used for turning, facing, boring, grinding and milling operations
- Collet 5C or 16C not included

Code No.	Type	A [in]	B [in]	C [in]	D [in]	F [in]	G	RPM	Weight [lbs]
7-862-0503	3975-5"-5C	4.92	3.62	0.16	3.74	4.25	3xM8	6000	11.46
7-862-0601	3975-6"-16C	6.30	4.51	0.16	4.92	5.51	3xM10	6000	20.5

3975



Standard accessories



1 Wrench + 1 Hex key

- 1
- 2
- 3
- 4
- 5

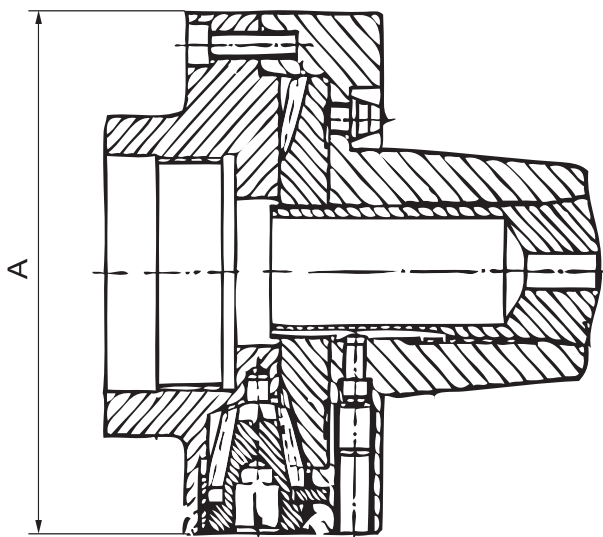

- 5C collet chucks
- Direct threaded mount
- The wrench operated scroll provides for uniform and distortion free clamping of workpieces while simultaneously allowing for a fast collet exchange
- Designed for use with 5C collets (385E) and can be used for turning, facing, boring, grinding and milling operations
- Collet 5C not included

Code No.	Type	A [in]	Thread size	RPM	Weight [lbs]
7-862-0515	3984-5"-5C	4.92	1-1/2" x 8	6000	12
7-862-0517	3984-5"-5C	4.92	2-1/4" x 8	6000	12

3984



Standard accessories



1 Wrench + 1 Hex key