

1
2
3
4
5
6

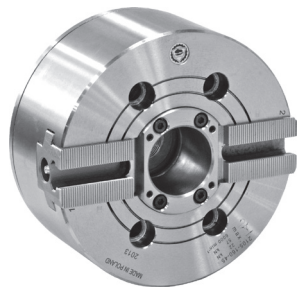

2105



- Manufactured from high grade alloy steel which extends machine life while providing higher rigidity and greater wear resistance
- The drawbar design results in its rigid structure and enables direct power transmission to the master jaws in direct area of jaw guideways – effective counteracting of the loss of gripping force and resulting in high power transmission efficiency
- Hardened and ground working surfaces ensure longer life with maintained accuracy and repeatability
- Master jaws secured against throw-off
- Master jaws lubricated directly
- Unbalance G 6.3

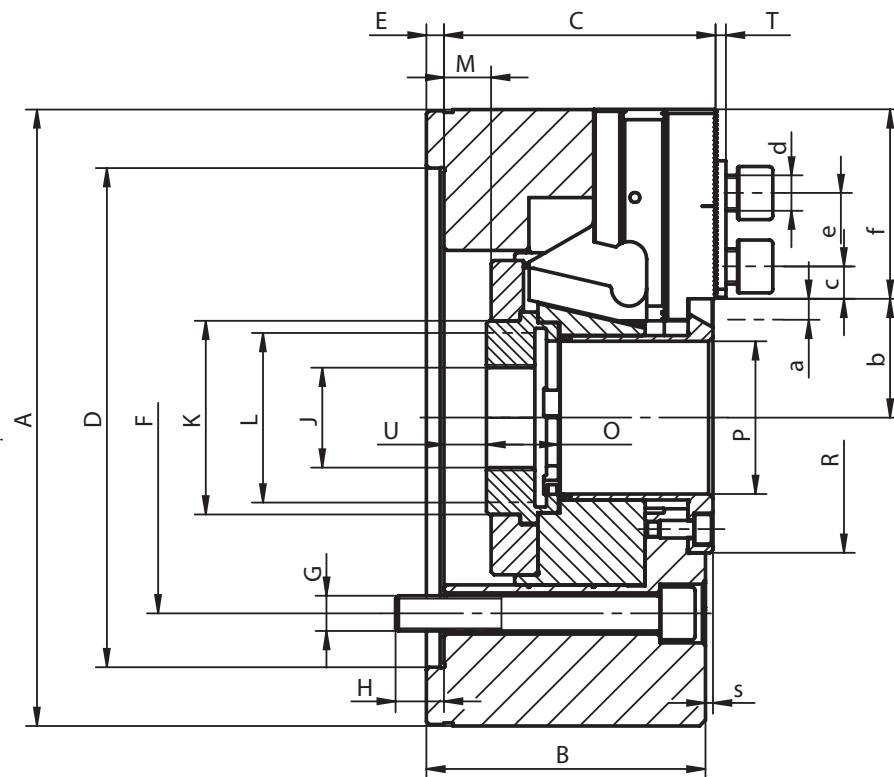
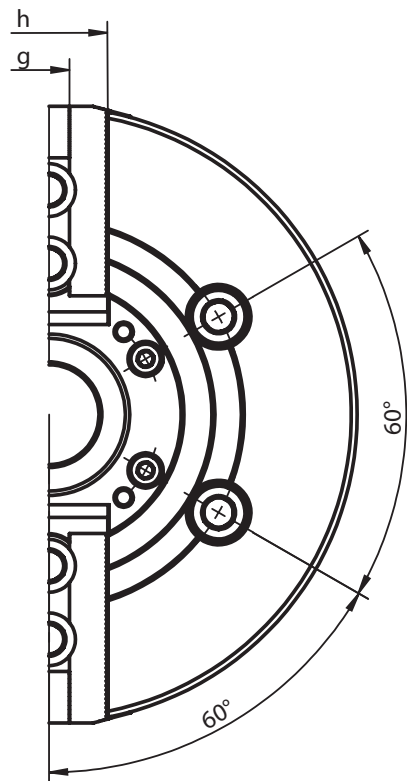

Standard Accessories

Mounting screws for chuck and jaw, T-nuts

Eye bolt (for Ø >200mm)

2105

Code No.	7-772-0600	7-772-0800	7-772-1000	7-772-1200
Type	2105-160-45	2105-200-52	2105-250-75	2105-315-91
A [mm]	169	210	254	315
B [mm]	81	95	106	108
C [mm]	79	93	104	106.5
Mounting D H6 [mm]	140	170	220	220
E [mm]	6	6	6	6
F [mm]	104.8	133.4	171.4	171.4
G [mm]	4 x M10	4 x M12	4 x M16	4 x M16
H [mm]	13.5	16.5	18	27
J [mm]	20	20	25	25
K [mm]	60	66	94	108
L max. [mm]	M55 x 2.0	M60 x 2.0	M85 x 2.0	M100 x 2.0
Max. drawbar stroke M [mm]	16 (13/-3)	22.5 (16/-6.5)	27 (19.5/-7.5)	27 (23/-4)
O [mm]	19	20.5	25	28
P [mm]	45	52	75	91
R [mm]	70	92	117	134
S [mm]	2.6	2.6	2.6	0.6
T [mm]	3	3.5	3.5	3.5
U min. [mm]	-5	-8	-18.5	-19
U max. [mm]	11	14.5	8.5	8
Jaw stroke a [mm]	3.5	5	6	6
Serration [in]	1/16"x90°	1/16"x90°	1/16"x90°	1/16"x90°
b min. [mm]	30.2	35.5	47.9	56.9
b max. [mm]	33.7	40.5	53.9	62.9
c min. [mm]	9	9.5	12.4	12.5
c max. [mm]	25	33	41	55
d [mm]	M12	M12	M16	M16
e [mm]	24	24.5	32	32
f [mm]	51	64.5	73	94
g H7 [mm]	17	17	21	21
h [mm]	38	40	45	52
Max. pulling force [kN]	15	25	31	38
Max. clamping force [kN]	38	62	80	96
Max. speed [rpm]	6,000	5,000	4,200	3,300
Moment of inertia [kgm ²]	0.056	0.165	0.315	0.779
Weight without top jaws [lbs]	26.46	48.50	77.16	125.66

Larger sizes available upon request!