

- 1
- 2
- 3
- 4
- 5
- 6



## 2404-K

KOMPATIBEL MIT KITAGAWA TYPE N  
INTERCHANGEABLE WITH KITAGAWA TYPE N



- Manufactured from high grade alloy steel which extends machine life while providing higher rigidity and greater wear resistance
- The drawbar design results in its rigid structure and enables direct power transmission to the master jaws in direct area of jaw guideways – effective counteracting of the loss of gripping force and resulting in high power transmission efficiency
- Hardened and ground working surfaces ensure longer life with maintained accuracy and repeatability
- Master jaws secured against throw-off
- Master jaws lubricated directly
- Unbalance G 6.3
- Chucks with Ø 500mm and greater are equipped with T-slots

135 - 400mm

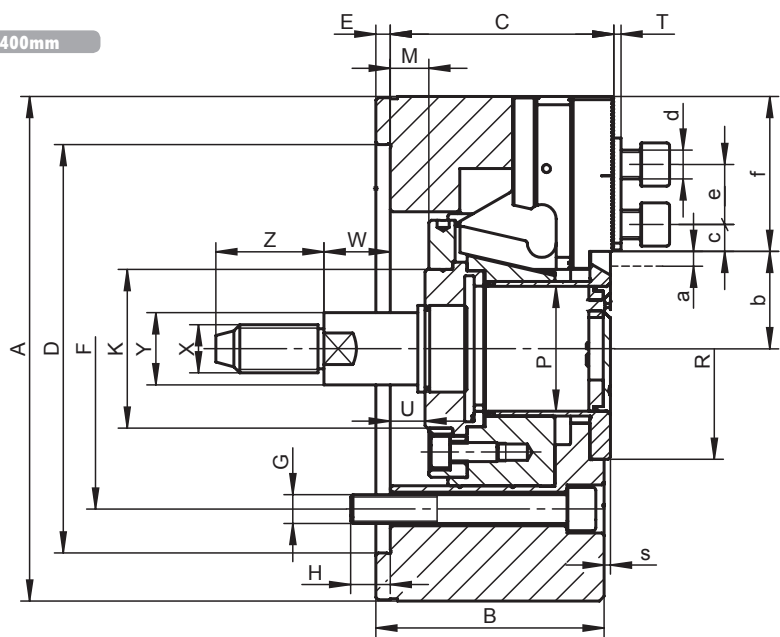
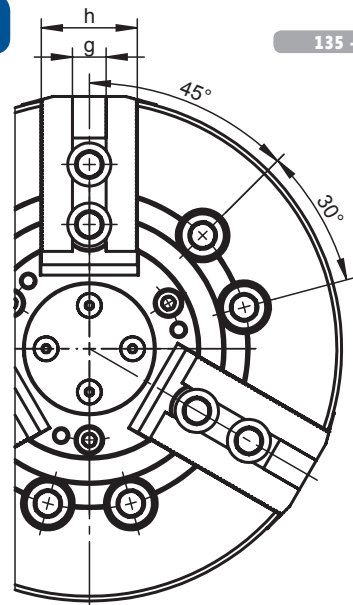

500 - 800mm

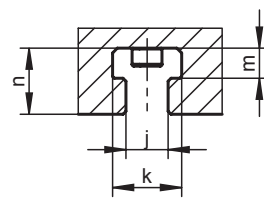
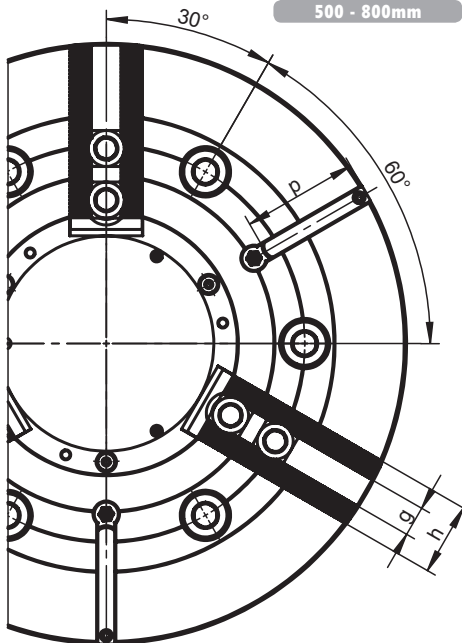

Standard Accessories

Mounting screws for chuck and jaw, T-nuts

Eye bolt (for Ø >200mm)

2404-K

Code No.	7-777-0600	7-777-0600	7-777-0800	7-777-1000	7-777-1200	7-777-1600	7-777-2000	7-777-2500	7-777-3200
Type	2404-135K	2404-160K	2404-200K	2404-250K	2404-315K	2404-400K	2404-500K	2404-630K	2404-800K
A [mm]	135	169	210	254	315	400	500	630	800
B [mm]	60	81	95	106	108	130	127	160	160
C [mm]	59.5	79	93	104	106.5	126.5	127	158	158
Mounting D H6 [mm]	110	140	170	220	220	300	380	520	520
E [mm]	4	6	6	6	6	6	6	8	8
F [mm]	82.6	104.8	133.4	171.4	171.4	235	330.2	463.6	463.6
G [mm]	3 x M10	6 x M10	6 x M12	6 x M16	6 x M16	6 x M20	6 x M24	6 x M24	6 x M24
H [mm]	14.5	13.5	16.5	18	27	28	35	34	34
K [mm]	45	60	66	94	108	140	182	230	284
Max. drawbar stroke M [mm]	10 (10/0)	16 (13/-3)	22.5 (16/-6.5)	27 (19.5/-7.5)	27 (23/-4)	34 (23/-11)	34.5 (16.8/-17.7)	44 (44/0)	44 (44/0)
P [mm]	34	45	52	75	91	120	160	200	255
R [mm]	56	70	92	117	134	164	220	275	330
S [mm]	1.5	2.6	2.6	2.6	0.6	0.5	3	4.1	4.1
T [mm]	2	3	3	3	2.5	5	4	4	4
U min. [mm]	-9.5	-5	-8	-18.5	-19	-23	-32.5	-22	-22
U max. [mm]	0.5	11	14.5	8.5	8	11	2	22	22
W [mm]	20.5	25.5	27.5	33	34	27	35	27	27
Z [mm]	35	40	45	55	55	55	50	50	50
X [mm]	M12	M16	M20	M24	M24	M24	M30	M30	M30
Y [mm]	20	24	30	36	36	36	42	42	42
Jaw stroke a [mm]	2.7	3.5	5	6	6	7.85	8	10	10
Serration [mm]	1.5x60°	1.5x60°	1.5x60°	1.5x60°	1.5x60°	1.5x60°	3.0x60°	3.0x60°	3.0x60°
b min. [mm]	24	30.2	35.5	47.9	56.9	74.65	97	134	162
b max. [mm]	26.8	33.7	40.5	53.9	62.9	82.5	105	144	172
c min. [mm]	7	9	10.5	11.7	13.2	12.5	16	16	16
c max. [mm]	20	25.5	33	41.7	60	51.5	86	116	166
d [mm]	M8	M10	M12	M12	M16	M20	M20	M20	M20
e [mm]	14	20	25	30	30	43	43	43	43
f [mm]	40.5	51	64.5	73	94	115	143.5	170	225
g H7 [mm]	10	12	14	16	21	25.5	25	25	25
h [mm]	25	38	40	45	52	60	60	70	70
j [mm]	-	-	-	-	-	-	14	22	22
k [mm]	-	-	-	-	-	-	23	37	37
m [mm]	-	-	-	-	-	-	10	16	16
n [mm]	-	-	-	-	-	-	21	35	35
p [mm]	-	-	-	-	-	-	87	100	160
Max. pulling force [kN]	17.5	22	34	43	56	71	90	100	100
Max. clamping force [kN]	36	57	86	111	144	180	200	200	200
Max. speed [rpm]	7,000	6,000	5,000	4,200	3,300	2,500	1,600	1,200	800
Moment of inertia [kgm <sup>2</sup> ]	0.018	0.057	0.15	0.31	0.73	2.15	5	16	48
Weight without top jaws [lbs]	13.89	28.66	51.81	85.98	134.48	262.35	370.38	709.89	1,188.29

Larger sizes available upon request!