

1
2
3
4
5
6



2604-K

INTERCHANGEABLE WITH KITAGAWA



- Manufactured from high grade alloy steel which extends machine life while providing higher rigidity and greater wear resistance
- The drawbar design results in its rigid structure and enables direct power transmission to the master jaws in direct area of jaw guideways - effective counteracting of the loss of gripping force and resulting in high power transmission efficiency
- Hardened and ground working surfaces ensure longer life with maintained accuracy and repeatability
- Master jaws secured against throw-off
- Master jaws lubricated directly
- Unbalance G 6.3

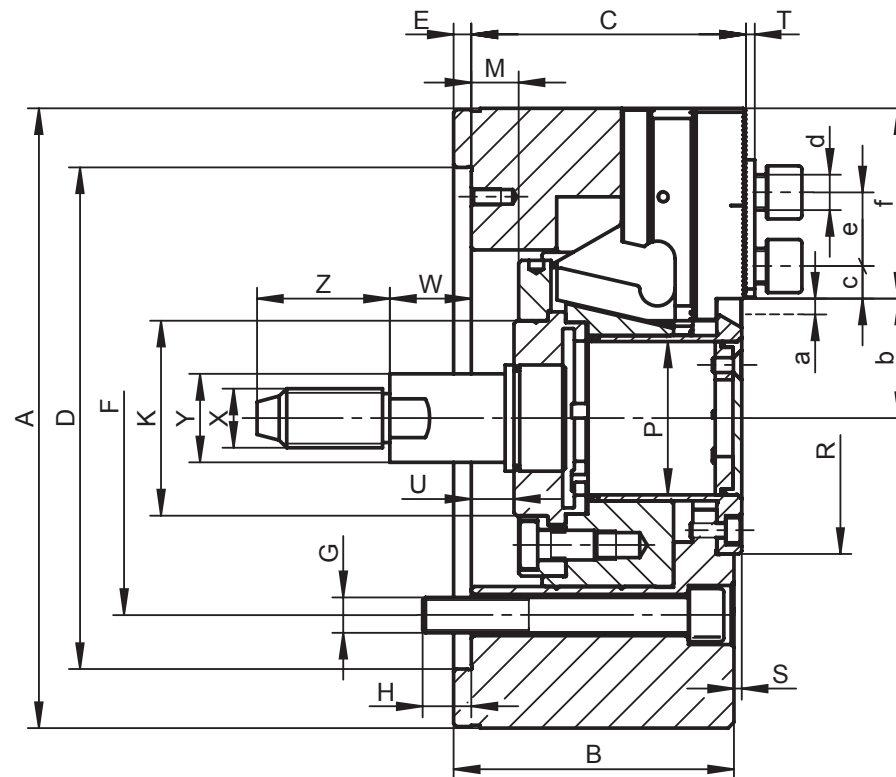
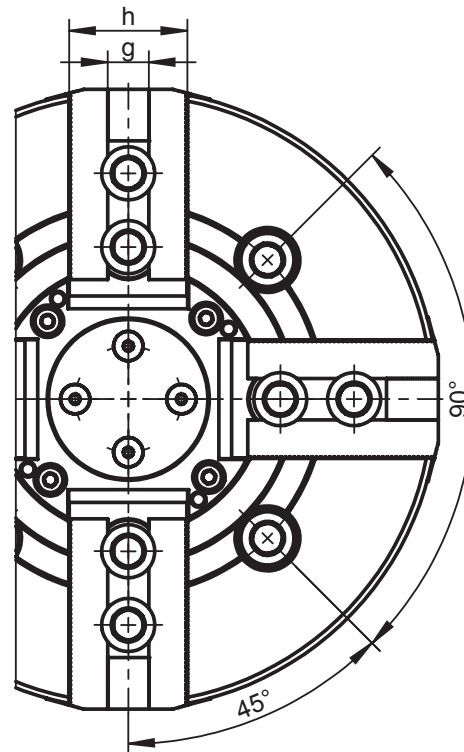

Standard Accessories

Mounting screws for chuck and jaw, T-nuts

Eye bolt (for $\varnothing > 200\text{mm}$)

2604-K



Code No.	7-779-0500	7-779-0600	7-779-0800	7-779-1000	7-779-1200
Type	2605-135K	2605-160K	2605-200K	2605-250K	2605-315K
A [mm]	135	169	210	254	315
B [mm]	60	81	95	106	108
C [mm]	59.5	79	93	104	106.5
Mounting D H6 [mm]	110	140	170	220	220
E [mm]	4	6	6	6	6
F [mm]	82.6	104.8	133.4	171.4	171.4
G [mm]	4 x M10	4 x M10	4 x M12	4 x M16	4 x M16
H [mm]	14.5	13.5	16.5	18	27
K [mm]	45	60	66	94	108
Max. drawbar stroke M [mm]	10 (10/0)	16 (13/-3)	22.5 (16/-6.5)	27 (19.5/-7.5)	27 (23/-4)
P [mm]	34	45	52	75	91
R [mm]	56	76	92	117	134
S [mm]	1.5	2.6	2.6	2.6	0.6
T [mm]	2	3	3	3	2.5
U min. [mm]	-9.5	-5	-8	-18.5	-19
U max. [mm]	0.5	11	14.5	8.5	8
W [mm]	20.5	25.5	27.5	33	34
Z [mm]	35	40	45	55	55
X [mm]	M12	M16	M20	M24	M24
Y [mm]	20	24	30	36	36
Jaw stroke a [mm]	2.7	3.5	5	6	6
Serration [mm]	1.5x60°	1.5x60°	1.5x60°	1.5x60°	1.5x60°
b min. [mm]	24	30.2	35.5	47.9	56.9
b max. [mm]	26.8	33.7	40.5	53.9	62.9
c min. [mm]	7	9	10.5	11.7	13.2
c max. [mm]	20	25.5	33	41.7	60
d [mm]	M8	M10	M12	M12	M16
e [mm]	14	20	25	30	30
f [mm]	40.5	51	64.5	73	94
g H7 [mm]	10	12	14	16	21
h [mm]	25	38	40	45	52
Max. pulling force [kN]	17.5	22	34	43	56
Max. clamping force [kN]	36	57	86	111	144
Max. speed [rpm]	6,000	5,000	4,300	3,600	2,800
Moment of inertia [kgm ²]	0.014	0.047	0.133	0.315	0.779
Weight without top jaws [lbs]	12.79	26.46	48.50	78.26	126.77

Larger sizes available upon request!