

Gear drive (m=3.5; z=108; Dp=378; x=0,53)

* All dimensions on the drawing are in [mm]

- Powered by a special gear transmission system, for use on lathes equipped with a power transmission system
- Especially designed for accurate mounting of pipes and other long components on the lathe spindle, with mounting of two chucks one at each end
- The double spindle configuration increases clamping force and clamping stability

2534-L



Code No.	Type	Weight without top jaws [lbs]
7-755-1610L	2534-400L	227.08

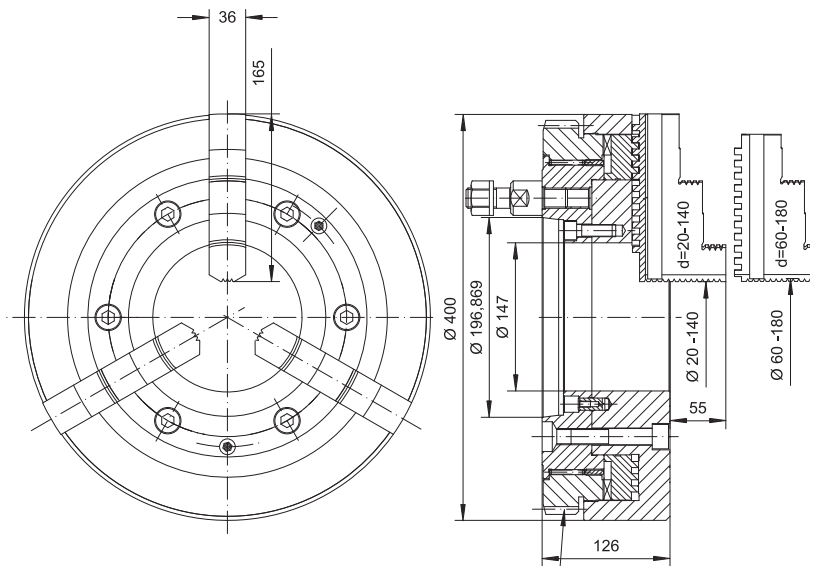

Gear drive (m=3.5; z=108; Dp=378; x=0,53)

* All dimensions on the drawing are in [mm]

- Powered by a special gear transmission system, for use on lathes equipped with a power transmission system
- Especially designed for accurate mounting of pipes and other long components on the lathe spindle, with mounting of two chucks one at each end
- The double spindle configuration increases clamping force and clamping stability

2534-P



Code No.	Type	Weight without top jaws [lbs]
7-755-1610P	2534-400P	227.08