

- INTERCHANGEABLE WITH KITAGAWA B-200 SERIES
- 1.5 X 60° JAW SERRATION

2605-K

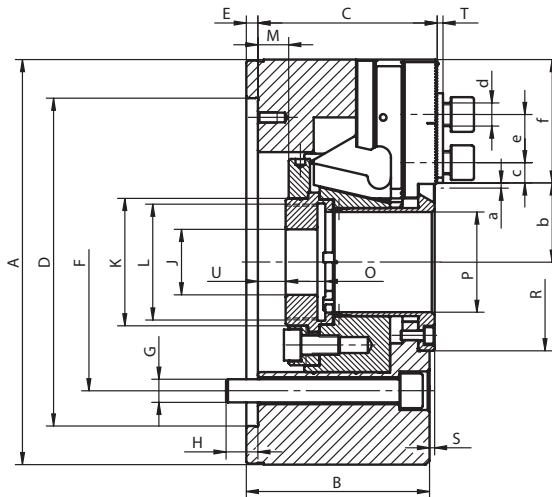
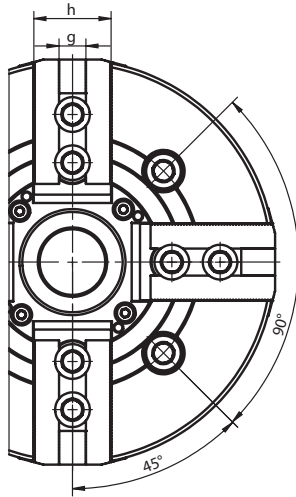

- Manufactured from high grade alloy steel which extends chuck life while providing higher rigidity and greater wear resistance
- The drawbar design results in a rigid structure while enabling direct power transmission to the master jaws in the area of the jaw guideways
- This effectively counteracts the loss of gripping force resulting in high power transmission efficiency
- Hardened and ground working surfaces ensure longer life with maintained accuracy and repeatability
- Master jaws secured against throw-off
- Master jaws lubricated directly
- G 6.3 balance grade

Standard Accessories

Soft Top Jaws

Mounting screws for chuck and jaw, T-nuts

Eye bolt (for Ø >200mm)

Code No.	7-783-0500	7-783-0600	7-783-0800	7-783-1000	7-783-1200
Type	2605-135-34K	2605-160-45K	2605-200-52K	2605-250-75K	2605-315-91K
A [mm]	135	169	210	254	315
B [mm]	60	81	95	106	108
C [mm]	59.5	79	93	104	106.5
Mounting D H6 [mm]	110	140	170	220	220
E [mm]	4	6	6	6	6
F [mm]	82.6	104.8	133.4	171.4	171.4
G [mm]	4 x M10	4 x M10	4 x M12	4 x M16	4 x M16
H [mm]	14.5	13.5	16.5	18	27
J [mm]	12	20	20	25	25
K [mm]	45	60	66	94	108
L max. [mm]	M40 x 1.5	M55 x 2.0	M60 x 2.0	M85 x 2.0	M100 x 2.0
Max. drawbar stroke M [mm]	10 (10/0)	16 (13/-3)	22.5 (16/-6.5)	27 (19.5/-7.5)	27 (23/-4)
O [mm]	20	19	20.5	25	28
P [mm]	34	45	52	75	91
R [mm]	56	76	92	117	134
S [mm]	1.5	2.6	2.6	2.6	0.6
T [mm]	2	3	3	3	2.5
U min. [mm]	-9.5	-5	-8	-18.5	-19.0
U max. [mm]	0.5	11	14.5	8.5	8
Jaw stroke a [mm]	2.7	3.5	5	6	6
Serration [mm]	1.5x60°	1.5x60°	1.5x60°	1.5x60°	1.5x60°
b min. [mm]	24	30.2	35.5	47.9	56.9
b max. [mm]	26.8	33.7	40.5	53.9	62.9
c min. [mm]	7	9	10.5	11.7	13.2
c max. [mm]	20	25.5	33	41.7	60
d [mm]	M8	M10	M12	M12	M16
e [mm]	14	20	25	30	30
f [mm]	40.5	51	64.5	73	94
g H7 [mm]	10	12	14	16	21
h [mm]	25	38	40	45	52
Max. pulling force [kN]	17.5	22	34	43	56
Max. clamping force [kN]	36	57	86	111	144
Max. speed [rpm]	6,000	5,000	4,300	3,600	2,800
Moment of inertia [kgm ²]	0.014	0.047	0.133	0.315	0.779
Weight without top jaws [lbs]	12.35	26.46	47.40	77.16	124.56

Chucks Supplied With Blank Draw Nut. Threaded Draw Nuts Available On Request

Larger sizes available upon request!