

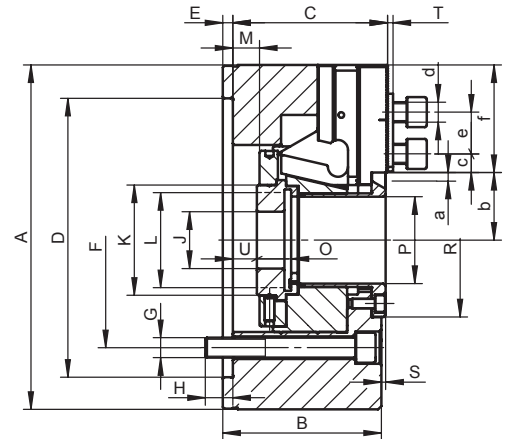

# 3-JAW POWER CHUCKS WITH LARGE THROUGH HOLE

**2405-K ZW**

- INTERCHANGEABLE WITH KITAGAWA BB-200 SERIES
- 1.5 X 60° JAW SERRATION

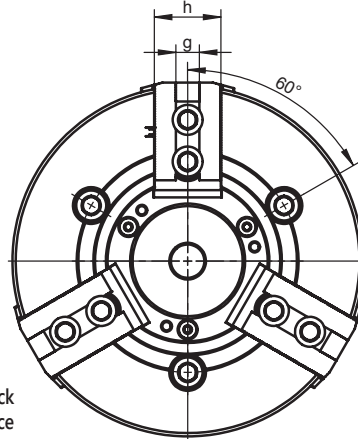

- Manufactured from high grade alloy steel which extends chuck life while providing higher rigidity and greater wear resistance
- The drawbar design results in a rigid structure while enabling direct power transmission to the master jaws in the area of the jaw guideways
- This effectively counteracts the loss of gripping force resulting in high power transmission efficiency
- Hardened and ground working surfaces ensure longer life with maintained accuracy and repeatability
- Master jaws secured against throw-off
- Master jaws lubricated directly
- G 6.3 balance grade

Standard Accessories

Soft Top Jaws

Mounting screws for chuck and jaw, T-nuts

Eye bolt (for Ø >200mm)

Code No.	7-781-0660	7-781-0880	7-781-1010	7-781-1220
Type	2405-160-53K	2405-200-66K	2405-250-81K	2405-315-110K
A [mm]	169	210	254	315
B [mm]	81	95	106	108
C [mm]	79	93	104	106.5
Mounting D H6 [mm]	140	170	220	300
E [mm]	6	6	6	6
F [mm]	104.8	133.4	171.4	235
G [mm]	3 x M10	3 x M12	3 x M16	3 x M20
H [mm]	13.5	16.5	18	29
J [mm]	20	20	25	25
K [mm]	68	86	96	130
L max. [mm]	M62x2	M75x2	M90x2	M120x2
Max. drawbar stroke M [mm]	16 (13/-3)	22.5 (16/-6.5)	27 (19.5/-7.5)	27 (23/-4)
O [mm]	19	20.5	25	28
P [mm]	53	66	81	110
R [mm]	78	98	123	154
S [mm]	2.6	2.6	2.6	0.6
T [mm]	3	3	3	2.5
U min. [mm]	-5	-8	-18.5	-19
U max. [mm]	11	14.5	8.5	8
Jaw stroke a [mm]	3.5	5	6	6
Serration [mm]	1.5x60°	1.5x60°	1.5x60°	1.5x60°
b min. [mm]	34	43.5	50	67
b max. [mm]	37.5	48.5	56	73
c min. [mm]	9	10.5	11.7	13.2
c max. [mm]	24	29	41.7	54
d [mm]	M10	M12	M12	M16
e [mm]	20	25	30	30
f [mm]	47.5	58.5	73	85
g H7 [mm]	12	14	16	21
h [mm]	38	40	45	52
Max. pulling force [kN]	22	34	43	56
Max. clamping force [kN]	57	86	111	144
Max. speed [rpm]	6,000	5,000	4,200	3,300
Moment of inertia [kgm <sup>2</sup> ]	0.057	0.15	0.31	0.73
Weight without top jaws [lbs]	26.46	46.30	73.85	121.25

Chucks Supplied With Blank Draw Nut. Threaded Draw Nuts Available On Request

Larger sizes available upon request!