

## JAW INSERTS

1

2

3

4

5

### CLAMPING INSERTS FOR MACHINE VISES

- Inclined inserts, for horizontal clamping of round workpieces, hardened and ground
- 1-pc/set

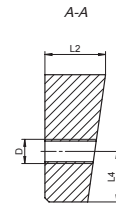
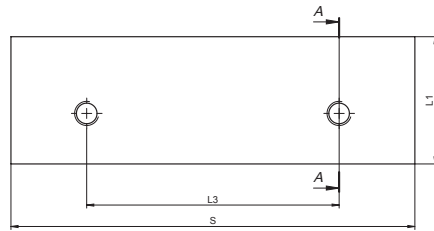

Code No.	S	L1	L2	L3	L4	D	Clamping range Ø horizontal	For Type
	[mm]							
7-292-044	100	32.4	18	63	14.0	M8	8-30	6517, 6518
7-292-045	125	40.0	22	80	15.8	M10	12-38	6517, 6518
7-292-046	160	50.4	24	100	20.0	M10	14-48	6517, 6518
7-292-048	200	63.0	30	125	25.0	M12	18-61	6517, 6518

### CLAMPING INSERTS FOR MACHINE VISES

- Four sided, prism inserts, vertical and horizontal prism, horizontal recess, hardened and ground
- 1-pc/set

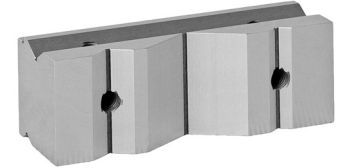
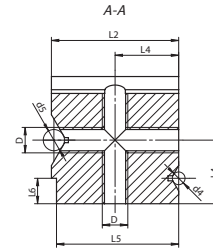
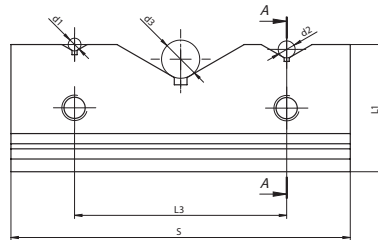

Code No.	S	L1	L2	L3	L4	L5	L6	D	Clamping range Ø vertical			Clamping range Ø horizontal		For Type
	[mm]									d1	d2	d3	d4	
7-205-903	80	30	30	50	15	28.8	6	M6	3-11	4-23	9-59	3-11	4-23	6542
7-205-904	100	35	35	60	17.5	33.0	6	M8	3-15	5-27	11-69	3-15	5-27	6542

### CLAMPING INSERTS FOR MACHINE VISES

- Prism inserts. Two vertical prism for clamping of round workpieces
- 1-pc/set

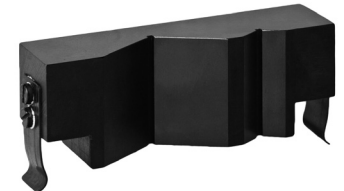
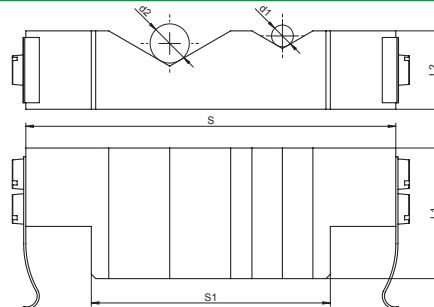

Code No.	Size	S	S1	L1	L2	Clamping range Ø vertical		For Type
	[mm]						d1	
7-260-903	80	70	45.9	26	16	4-18	8-45	6540
7-260-904	100	85	54.9	30	18	5-25	9-55	6540
7-260-905	125	105	74.9	38	25	6-28	14-90	6540
7-260-906	160	138	101.9	44	33	7-38	20-135	6540