

- 1
- 2
- 3
- 4
- 5

### 5859

- Due to the three dividing plates, division into the required number of sections is obtained with an accuracy of 1'
- Dividing means of graduated drum with 1'30"
- Centering Morse taper sleeves are hardened and ground, extending machine life
- Depending on the size gear ratio is 1:60, 1:90, 1:120

- Standard accessories**
- Three dividing plates with clamping bolts
  - Slot nuts
  - Table lever

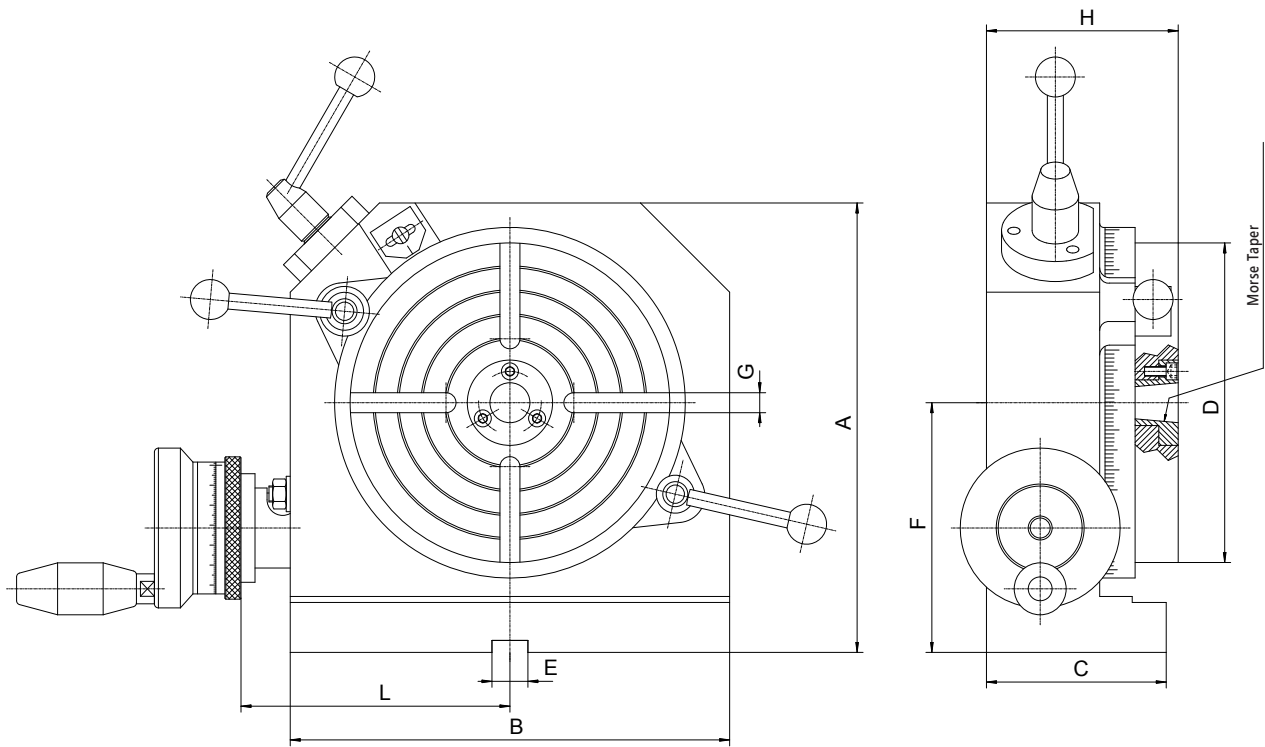

Code No.	Type	Worm ratio	A	B	C	D	E	F	G	H	L	Morse Taper	Adapters Ø	Chucks Ø	Tailstocks		Permissible weight of workpieces		Weight
															5818	5819	Horizontal	Vertical	
															[mm]				
7-621-006	5859-160	1:60	225	200	90	160	14	125	4x10	96	127	3	160	160	125	95+130	85	40	44.1
7-621-008	5859-200	1:60	270	240	95	200	14	150	4x10	98	147	3	160, 200	160, 200	-	130+170	120	45	55.1
7-621-010	5859-250	1:90	318	285	115	250	18	175	4x12	115	175	3	250	250	-	170+200	160	80	121.3
7-621-012	5859-320	1:90	374	348	115	320	18	200	4x12	120	207	3	315, 250	315, 250	200	170+200	210	110	176.4
7-621-016	5859-400	1:90	465	430	125	400	18	250	6x14	135	248	4	400	400	250	220+250	350	125	269.0
7-621-020	5859-500	1:120	582	535	170	500	18	315	8x16	175	310	5	-	-	-	-	420	200	573.2