

HOLD-TIGHT MACHINE VISE

6523

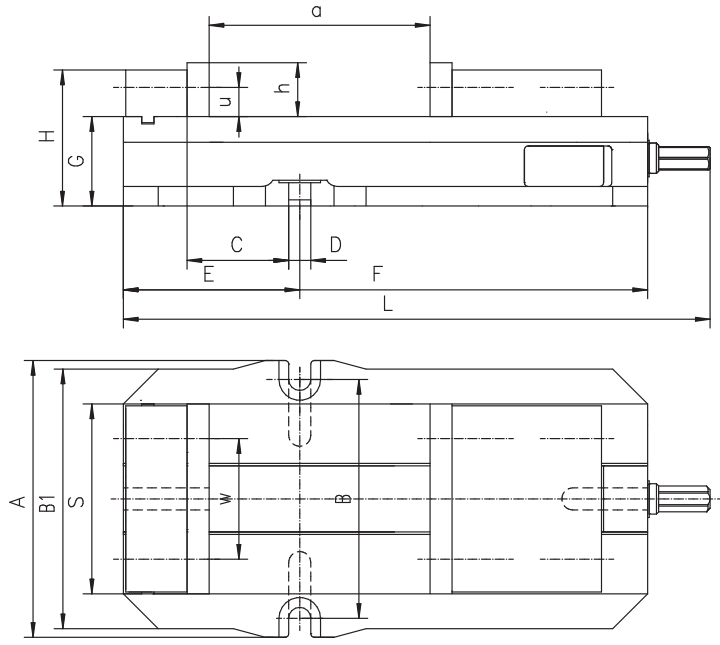

- Features:**
- Possible to secure the jaws in 4 different positions, increasing the clamping range of workpieces
 - Steel jaw inserts, formed according to client's requirements, are hardened and ground, ensuring longer life with maintained accuracy and repeatability
 - Body and movable jaw are made of high-quality cast iron
- Application:**
- Designed for use with milling machines, drill presses, grinders, etc. and other work that requires high accuracy and safe clamping
- Standard accessories:**
- Handcrank
 - Slot nuts

MAXIMUM LENGTH OF WORKPIECE (MM) DEPENDS ON HOW THE JAW INSERTS ARE SECURED

Matching swivel base



Accessories 19-31

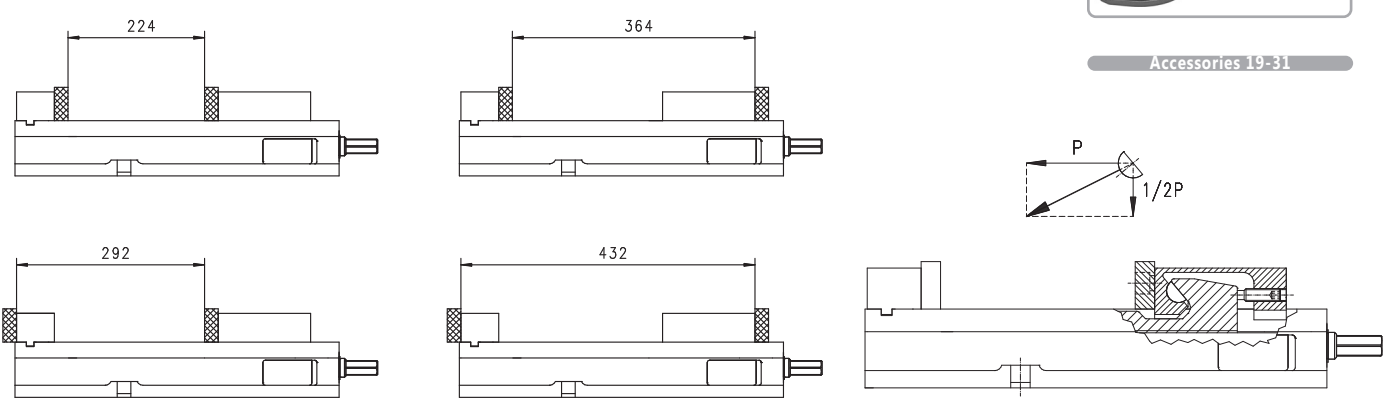

Code No.	Type	S	A	B	B1	C	D	E	F	G	H	L	a	h	u	w	Max. clamping force	Weight
		[mm]																
7-220-0068	6523-155L	155L	226	195	212	83	18	144	428	73.025	111	479	224	44	23.8	98.4	4,500	75.3