

MORSE TAPER

Standard features of the tools:

- Manufactured with Chrome Manganese steel
- Carburized with depth of case 0.7 mm
- Hardened and precision ground
- Surface hardness HRC 58±2
- Taper angle: tolerance AT3

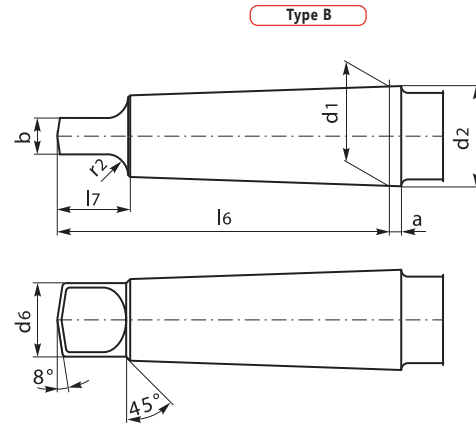
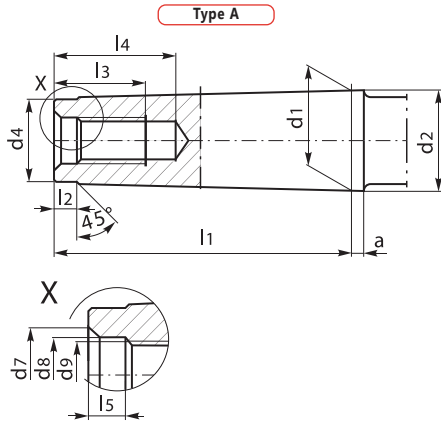

K MT	a [in]	b [in]	d ₁ [in]	d ₂ [in]	d ₄ [in]	d ₆ [in]	d ₇ [in]	d ₈ [in]	d ₉ [imperial]	d ₉ [metric]	l ₁ [in]	l ₂ [in]	l ₃ [in]	l ₄ [in]	l ₅ [in]	l ₆ [in]	l ₇ [in]	r ₂ [in]	a/2
0	0.118	0.154	0.356	0.362	0.236	0.236	-	-	-	-	1.969	0.157	-	-	-	2.224	0.413	0.157	1°29'27"
1	0.138	0.205	0.475	0.480	0.354	0.343	0.335	0.252	-	M6	2.106	0.197	0.630	0.866	0.157	2.441	0.531	0.197	1°25'43"
2	0.197	0.248	0.700	0.709	0.551	0.531	0.520	0.413	3/8-16 UNC	M10	2.520	0.197	0.945	1.240	0.197	2.953	0.63	0.236	1°25'50"
3	0.197	0.311	0.938	0.949	0.748	0.728	0.630	0.512	3/8-16 UNC	M12	3.189	0.276	0.945	1.319	0.217	3.701	0.787	0.276	1°26'16"
4	0.256	0.469	1.231	1.244	0.984	0.965	0.846	0.669	1/2-13 UNC	M16	4.035	0.354	1.260	1.673	0.323	4.626	0.945	0.315	1°29'15"
5	0.256	0.626	1.748	1.760	1.406	1.406	1.024	0.827	5/8-11 UNC	M20	5.098	0.394	1.575	2.067	0.394	5.886	1.142	0.394	1°30'26"
6	0.315	0.748	2.494	2.512	2.008	2.008	1.260	0.984	1-8 UNC	M24	7.165	0.630	1.850	2.421	0.453	8.268	1.575	0.512	1°29'36"
7	0.374	1.122	3.270	3.287	2.598	2.630	-	-	-	-	9.862	0.709	-	-	-	11.26	2.126	0.748	1°29'22"